

Always check the material before starting work in order to avoid problems with visible defects. Please inform GERFLOR of any visible defects discovered and do not start work without their approval.

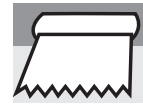

Ambient temperature



Floor temperature

IN ACCORDANCE WITH LOCAL STANDARDS

1. MATERIAL INSPECTION AND SUBFLOOR RECOMMENDATIONS

1.1. MATERIAL INSPECTION

- Inspect all materials carefully to verify that the correct colours, batch number, patterns, quality and quantities have been shipped as ordered. Do not install, cut, or fit any material that has visible defects.
- Differences of width (tolerances) may exist between the rolls.
- A contractor who installs material that has visible defects or damage without the prior consent of GERFLOR deems the product acceptable for installation and therefore accepts full responsibility.

1.2. SUBFLOOR RECOMMENDATIONS

- To prevent the presence of moisture or water in the underside of PVC floor, measure the moisture content before installing the PVC flooring. Moisture levels must be in accordance with local standard. Common reference for moisture tests is performed as per ASTM F2170- 11 "Standard Test Method for Determining Relative Humidity in Concrete Floor Slabs Using In-Situ Probes". Substrate moisture levels shall not exceed for concrete slab with an effective moisture vapor barrier 5-lbs / 80% RH.
- Prepare the subfloor as necessary to provide a smooth, flat, dry and clean surface on which to install.
- Apply a suitable epoxy damp proof membrane if necessary.

2. UNROLLING THE MATERIAL

Minimum ambient temperature for laying : must be in accordance with the local standard.

- Mark the longitudinal and transverse axis on the subfloor. These will ensure all widths are straight when positioned.
- Fully unroll the material, ensuring the rolls are positioned in sequence (see roll number on label and diagram below). In halls where multiple lengths are required, always unroll the rolls from the centre of the hall, taking the inside of the roll in the direction of the perimeter.
- Starting from the centre, lay the first width along the longitudinal line ensuring it is straight.
- Leave a gap of 1cm between widths. This allows the material to fully acclimatise in both length and width. Widths can be overlapped if the area is smaller.
- Let the material to relax over a period of 24 hours. This will allow any tension within the material to be released prior to adhesion.

1	2
3	4
5	6
7	8
9	10

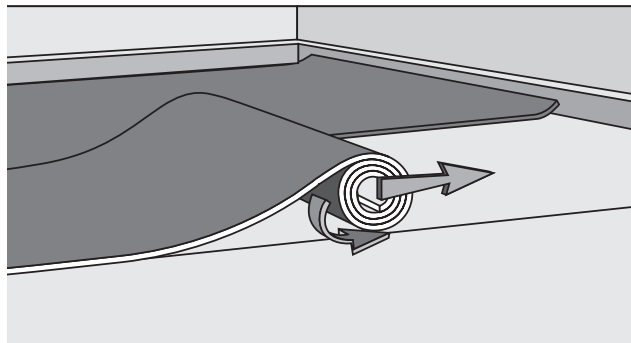

DIRECTION OF LAYING:



	PLAIN COLOUR	IMITATION FLOOR COVERING (WOOD...)
Recreation 45 Leisure	Same Direction	Same Direction
Recreation 65 Leisure	Same Direction	Same Direction
-	-	-

3. POSITIONING THE FLOORING

After acclimatising, the material can be positioned. Working from the first piece placed on the centreline, pull the widths together leaving a maximum gap of 0.5-1 mm.

Respect the laying direction and the order of rolls as over.

After positioning entire floors need to check surface condition in same level.

4. ADHERING THE FLOORING

- Adhering the material can start 24 hours after the material acclimatisation period.
- The flooring should be adhered using an acrylic dispersion adhesive and applied with an A2 spatula (according to TKB standard).
- Ensure that the adhesive is compatible with the subfloor and the material backing.
- Follow the adhesive manufacturers recommendations.

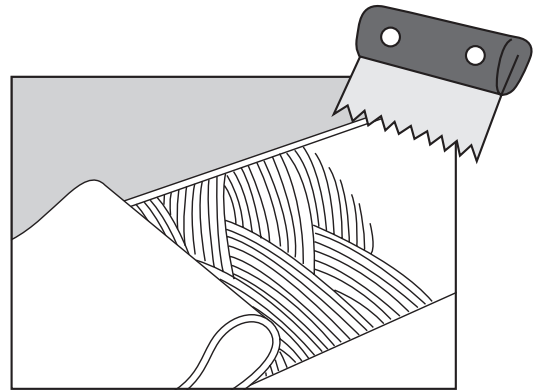
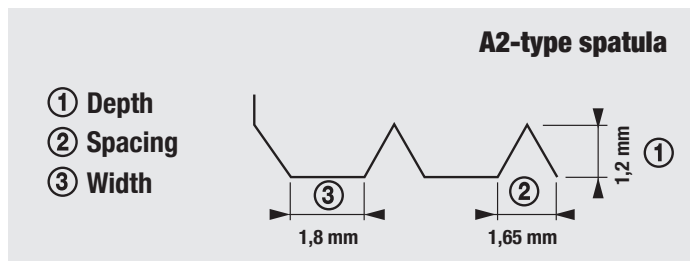

IMPORTANT:

- Forbid any trafficking for 48 hours after laying and 72 hours for any furniture movement.
- Follow carefully the recommendations of the adhesive manufacturer.

Recommendations for good adhesion:

- Respect the waiting time (open time) which depends on the temperature, ambient hygrometry, porosity of the subfloor and the adhesive coverage. If the flooring is applied to adhesive with insufficient waiting time, it will bubble.
- If the flooring is applied to adhesive which has gone past its open time, there will be insufficient adhesive transfer to the underside of the floor finish.

■ 4.1. LAYING THE LENGTH

- To adhere, pull the individual widths back to halfway.
- Start by pulling back the pieces on each side of the centreline and apply the adhesive. When the adhesive is ready, begin to place the material into the adhesive, ensuring the material remains on the centreline.
- Pull back the opposite end to halfway and apply the adhesive. When the adhesive is ready, repeat the process of placing the material into the adhesive. Continue to adhere the remaining widths, ensuring that when placed they sit edge to edge with a maximum gap of 1mm.

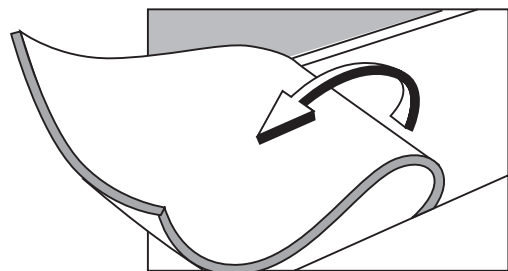

■ 4.2. SMOOTHING AND ROLLING

It is essential and carried out in two stages:

- Smooth out the material using a cork board to ensure good initial contact with the adhesive and expel any trapped air pockets.
- Final rolling of the whole surface with a flooring roller.

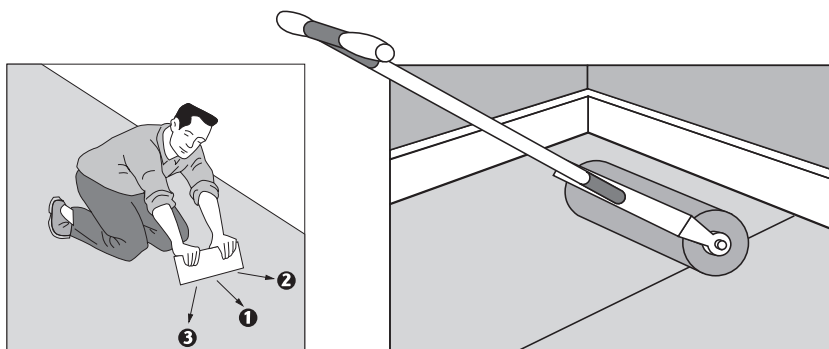

4.3. HOT WELDING (12 HOURS AFTER STICKING-DOWN)

4.3.1 – Grooving / Chamfering

It is necessary to groove through all the solid PVC layer. Leave a gap of 0.5-1 mm to allow the chamfering tool to be guided.

There are two chamfering methods:

- Manual using an appropriate tool (triangle, manual groover).

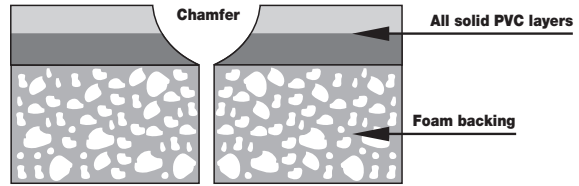

Triangular scraper, Ref. : 95185 by ROMUS



Linéa, Ref. : 95101 by ROMUS



Master Turbo, Ref. : 95200 by ROMUS



Swift groover Ref. : 262 611 400 by JANSER



Pico Groover, Ref. : 95122 by ROMUS

- Mechanical using an electric grooving machine fitted with a 3.3 mm width circular blade. The entire thickness of the wear layer must be chamfered, but not the foam underlay.

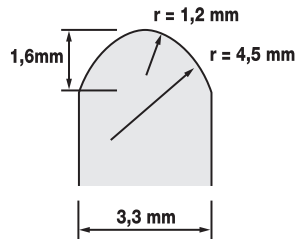

Profil of a circular saw blade

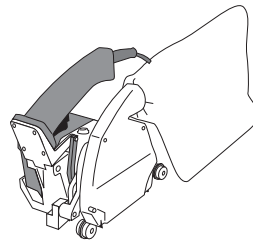

Groover or router

4.3.2 – Heat welding

NOTE: Always practice on a scrap piece of material first to assure proper temperature and speed. Doing so will prevent failures.

Manual weld with a SPEED NOZZLE

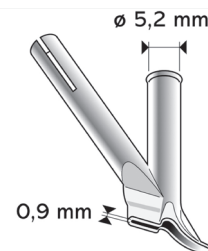
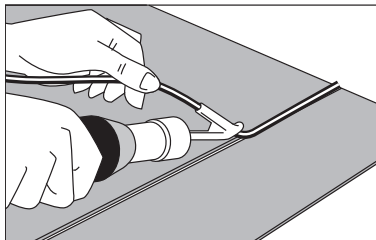

Use the RAPID ULTRA nozzle, diameter 5 mm, air inlet 0.9 mm, Ref.: 224 800 007 from JANSER or 95027 from ROMUS or the narrow nozzle on the automatic welder.

Weld with welding robot (required on large project)

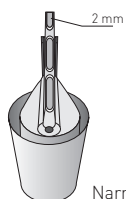

Narrow Nozzle

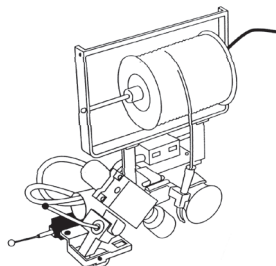

Use a Universal or Unifloor type LEISTER welder with electronically controlled hot air blower with special multiple fine jets. PVC Nozzle references:
ROMUS: 95254
LEISTER: 105.407
JANSER: 225 860 040

4.3.3 – Trimming weld rod

Trimming must be done in two passes. Using a trimming tool sharpen in the middle only, such as the MOZART, is recommend:

First stage:

Should be done with the spacer in place; 0.7 mm spacer is recommended.

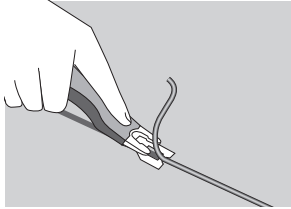

Second stage:

Second trim has to be done with the blade only (spacer retracted). This method prevents concave welds and must be done when the rod is cold.

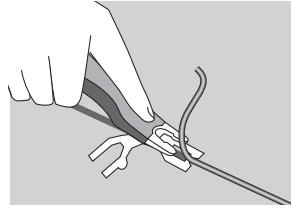

Available from ROMUS
Ref.: 95130
Spare blade:
Ref.: 95129

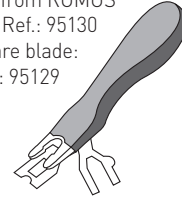

5. FINISHING

A circle cutter fitted with a centring device (part 262 262 500 – JANSER) can be used to achieve attractive trims around openings.



Use of painting:

In case of use of painting, in order to have good results through duration, use following solutions:

- **RECREATION LEISURE 45/65:**

use a water-based polyurethane paint for game lines as TLD AQUA PAINT which can be ordered from GERFLOR.

IMPORTANT: commissioning time frames

- For normal foot traffic, commission the floor no earlier than 48 hours after work completion.
- For installing sports equipment and rolling traffic, a period of 72 hours is required before commissioning.
- Because of foam underlay thickness, weight distribution plates must be installed under heavy static and dynamic loads.